

LT8-300/LT8-300P Owner's Guide

David White[®]

LT8-300 (Model 44-8870)

LT8-300P (Model 44-8871)

FOR CUSTOMER SERVICE,
PARTS AND REPAIR

CALL

815-432-5237



Limited Lifetime Warranty

David White ("Seller") warrants this David White optical instrument to be free from defects in material and/or workmanship. If, upon inspection, this instrument shall be proven to Seller's satisfaction to be defective, it shall be repaired or replaced, at Seller's option at no charge and returned to the original purchaser ("Buyer"), transportation prepaid. This warranty is not transferrable. Seller's sole obligation and Buyer's remedy hereunder shall be limited to such repair or replacement with these provisions:

1. The instrument is returned properly packaged transportation prepaid and insured by the Buyer to David White accompanied by proof of ownership (copy of sale or receipt).
2. The instrument, upon inspection of Seller, is determined to be defective due to material and/or workmanship and is in original condition, exception only ordinary wear resulting from normal usage.

SELLER SHALL NOT BE LIABLE FOR ANY
CONSEQUENTIAL, INCIDENTAL OR CONTINGENT
DAMAGES WHATSOEVER

Limitations and Exclusions

1. The foregoing warranty does not apply to David White instruments subjected to negligence, accident, improper operation or maintenance or storage; instruments damaged by transit or circumstances beyond Seller's control; instruments modified or damaged due to unauthorized repairs made by other than David White or authorized David White service center personnel.
 2. The foregoing warranty does not apply to instrument accessories or include general maintenance and service such as cleaning, lubrication or adjustment (i.e. calibration) of this instrument unless required as a result of material or workmanship defect.
- If upon examination of instrument, Seller determines that additional repairs or services not covered under this warranty are required, Seller shall notify Buyer of such charges and will proceed with said services or repairs only after authorization is received from Buyer.
3. The foregoing warranty does not apply to David White instruments damaged in transit to or from David White or a David White authorized service center.

THE FOREGOING WARRANTIES ARE EXCLUSIVE AND IN LIEU OR ALL OTHER WARRANTIES, EXPRESS OR IMPLIED, INCLUDING, BUT NOT LIMITED TO, THE IMPLIED WARRANTIES OF MERCHANTABILITY AND FITNESS FOR A PARTICULAR PURPOSE.

David White
P.O. Box 359, Watseka, IL 60970 USA
Website: www.davidwhite.com E-mail: sales@davidwhite.com

With David White your sights are set on precision and accuracy.

Congratulations! You've purchased a David White builder/contractor instrument, American made and known throughout the world for precision and accuracy.

The purpose of this booklet is to acquaint you with the instrument, its components, proper care and handling.

Our levels, level-transits and transits are constructed to withstand extremely rugged field use. Like all precision instruments, however, they should be treated with reasonable care to prolong life and accuracy.

All instruments are adjusted when they are shipped from the factory. It is the customer's responsibility to check and to ensure instruments are adjusted prior to using.

David White is not responsible for errors caused by instruments that are out of adjustment.

Contact your distributor, dealer or David White for information on the nearest facility to check if your instrument is properly adjusted.

All specifications are subject to change without notice.

All components not described on pages 3-4, including adjustment screws and nuts, have been factory set and should not require handling or readjustment. Tampering with these factory-adjusted components may impair accuracy or damage the instrument. Only trained technicians should service this instrument.

Specifications

LT8-300/LT8-300P Level-Transit

Optimum sighting range: Recommended job range up to 400 ft.
Accuracy range: Recommended for jobs requiring accuracy within $\frac{3}{16}$ " @ 150 ft.

Instrument Service and repair.

Your David White instrument is a precision-made optical instrument and like all good precision tools requires reasonable care and careful handling. It is recommended that all instruments be serviced by a reliable instrument repair station at least once a year to insure accuracy and reliable performance.

Repair or warranty service may be obtained from an authorized service center or directly from David White. Instruments sent for service or repairs should be addressed to our repair facility at:

Attn: Repair Department
 David White
 255 W Fleming Street
 Watseka, IL 60970 USA

Or call David White Customer Service toll free
 (U.S. and Canada) at 815-432-5237 for more information.

E-mail: custserv@davidwhite.com

For your records:

Model No. LT8-300 or LT8-300P _____

Serial No. _____

Date Purchased _____

For owner identification, please complete and mail the registration card.

TELESCOPE

Length	8 ½" (216mm)
Minimum focus	6' (1.8m)
Aperture	1.257" (32mm)
Power	26X
Field of view	1°9' @ 100" (1.7m @ 100m)
No. of lenses	8
Stadia Ratio	1:100

HORIZONTAL CIRCLE

Graduation diameter	4 ⅝" (117mm)
Graduations	Ea. 1°
Numbers	Ea. 10°, 0-90-0°
Vernier	Double direct to 5 min.

VERTICAL ARC

Graduations	Ea. 1°
Numbers	Ea. 10°, 45-0-45°
Vernier	Double direct to 5 min.

CENTER

Wide-stance dual row ball bearings

LEVEL VIAL

110-120 sec. per 2mm

WEIGHT

Instrument only	9 ½ lbs.
Instrument case, 6 oz. plumb bob	14 ¼ lbs.

CASE

Double-walled polyethylene, safety orange

TRIPOD

Use a 3 ½ X 8 tripod for the LT8-300. Use a heavy-duty ⅝ X 11 tripod for the LT8-300P and LT8-300LP.

General Description.

LT8-300 Level-Transit

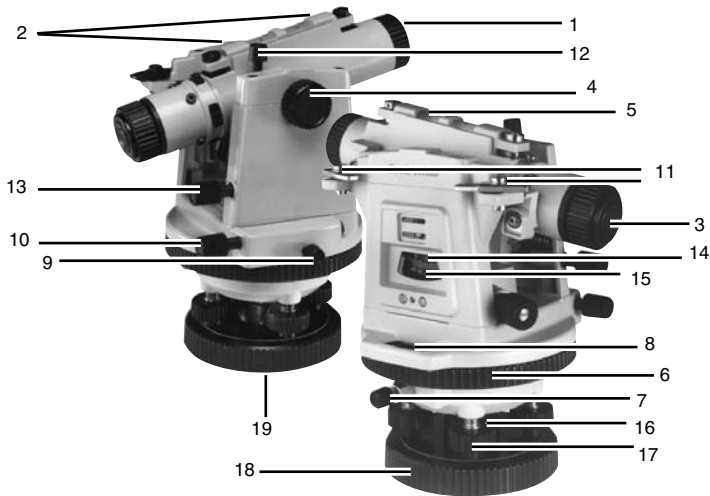

- | | | |
|--------------------------------|------------------------|------------------------------|
| 1. Telescope objective lens | 8. Horizontal vernier | 14. Vertical arc |
| 2. Sighting notches | 9. Horizontal clamp | 15. Vertical vernier |
| 3. Eyepiece | 10. Horizontal tangent | 16. Shifting center |
| 4. Focusing Knob | 11. Telescope lock | 17. Four leveling screws |
| 5. Instrument level vial | 12. Vertical clamp | 18. 3 1/2 X 8 thread base |
| 6. Horizontal graduated circle | 13. Vertical tangent | 19. Plumb bob hook and chain |
| 7. Horizontal circle lock | | |

The LT8-300P is identical to the LT8-300 level-transit, with the addition of the optical plummet. Information on using the optical plummet can be found on pages 9-12.

The **telescope (1)** provides a sharp image magnified 26 times. This means the object sighted appears 26 times closer than it would with the naked eye. The telescope comes with a detachable sunshade which protects the objective lense and reduces glare.

The **vial notches (2)** are used for preliminary sighting. To focus on an object, sight through the **eyepiece (3)** and bring the crosshairs into focus by turning the eyepiece cap. After the crosshairs are sharp and distinct, look through the eyepiece at the object and turn the **focusing knob (4)** until the object appears sharp and clear.

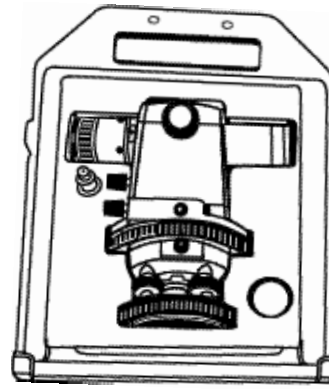

Storage Instructions:

- To ensure accurate calibration, lock levers must be disengaged and face down.
- Circle lock must face up.
- Focus knob must face up.

Care and handling.

1. Keep the instrument clean and free of dust and dirt. Clean the objective and eyepiece lenses using a soft brush or lens tissue. Rubbing with a cloth may scratch the lens coating and impair the view. Clean the instrument with a soft, non-abrasive cloth and mild detergent. Never use solvents or submerge the instrument in water. Do not attempt any disassembly.
2. If the instrument is wet, dry it before you return it to its case.
3. When the instrument is not being used, keep it in its carrying case.
4. When moving the instrument over a long distance, by foot or by vehicle, remove it from the tripod and place it in its protective case.
5. When moving a tripod-mounted instrument, handle with care. Carry only in an upright position. Do not carry over your shoulder or in a horizontal position. Improper handling may result in instrument damage.
6. Handle the instrument by its base when removing from the case or attaching to a tripod.
7. Never use force on any parts of the instrument. All moving parts will turn freely and easily by hand.
8. All precision instruments should be cleaned, lubricated, checked and adjusted **ONLY** at a qualified instrument repair station or by the manufacturer, at least once a year.

Sighting and focusing the telescope.

Aim the telescope at the object and sight first through the notches on the top of the level vial. Look through the telescope and focus the crosshairs. Then bring the object into focus.

Rotate the instrument until the crosshairs are positioned on or near the target. Tighten the horizontal clamp and make final settings with the tangent to bring the crosshairs exactly on point.

When sighting through the telescope, keep both eyes open. You will find that this eliminates squinting, will not tire your eyes and gives the best view through the telescope. Remember to avoid touching the tripod while sighting.

Stadia Reticle.

All David White Universal instruments have a glass stadia reticle with two additional horizontal lines for use in determining distance. Stadia ratio is 1:100, which indicates that the rod measurement between the upper and lower stadia lines multiplied by 100 is the distance from the center of the instrument to the rod.

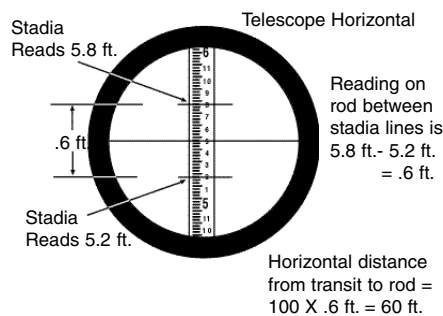

Removing the instrument from the tripod.

Unscrew the instrument base from the tripod head and remove the instrument from the tripod. When storing in the carrying case, disengage both lock levers and loosen the vertical clamp. Place instrument in case with lock levers facing down and focus knob facing up.

All focusing is internal. The telescope does not move outward or inward as objects are focused. David White Universal instruments utilize the smooth precision of a rack and pinion mechanism for focusing. Focus range is from six feet to infinity. For closer focus, turn the knob clockwise, For farther focusing, turn counterclockwise.

The instrument **leveling vial (5)** is factory aligned and is graduated to facilitate centering the bubble.

The **horizontal circle (6)** can be rotated for easy angle setting and reading and is divided in quadrants (0-90°). The circle is marked by degrees and numbered every 10 degrees.

The **horizontal circle lock (7)** assures accuracy by preventing the horizontal circle from being moved accidentally. Turn clockwise to tighten.

The **horizontal vernier (8)** permits dividing whole degrees into fractions of $\frac{1}{2}^\circ$ (5 minutes). See pages 13 and 14 for circle and vernier reading instructions.

Approximate horizontal sightings are held firmly in place by means of a **clamp (9)**. Then, precise horizontal settings can be made with the **tangent (10)**. The clamp must be hand tightened firmly before the tangent will function.

The LT8-300 Level-Transit is a combination instrument. Its telescope moves up and down 45 degrees, and rotates 360 degrees, to measure vertical and horizontal angles.

BOTH telescope lock levers (11) must be in a closed position when the instrument is to be used as a level; open when used for vertical sightings. They are shown in the open position.

The **vertical clamp (12)** holds the telescope at a vertical angle. Fine vertical settings can be made with the **tangent (13)**. The vertical clamp must be hand tightened firmly before the tangent will function.

The **vertical arc (14)** is divided in degrees and numbered every 10 degrees up to 45 degrees, for both upward and downward angles. A **vertical vernier (15)** permits dividing whole degrees into 5-minute increments. See pages 13 and 14.

The shifting **center (16)** facilitates accurate placement of the instrument over a point (see page 5). **Four screws (17)** are used for leveling the instrument. The instrument is mounted to the tripod by screwing the $3 \frac{1}{2} \times 8$ **base (18)** to the tripod head. A **hook and chain (19)** (not on LT8-300P) holds the plumb bob cord when setting the instrument up over a point.

Setting up your instrument.

(Instructions for using the optical plummet are found on pages 9-12.)

Each of the following steps is important in preparing to use your instrument.

1. It is important that the tripod is set up firmly. Make sure that the tripod points are well into the ground. On paved surfaces, be sure the points hold securely. The legs should have about a 3 ½ foot spread, **positioned so the top of the tripod head appears level.** If using a tripod with adjustable legs, be sure the leg clamp wing nuts are securely hand tightened.

2. Before setting up your instrument, be sure clamps are loosened and **both** telescope lock levers are in the closed position.

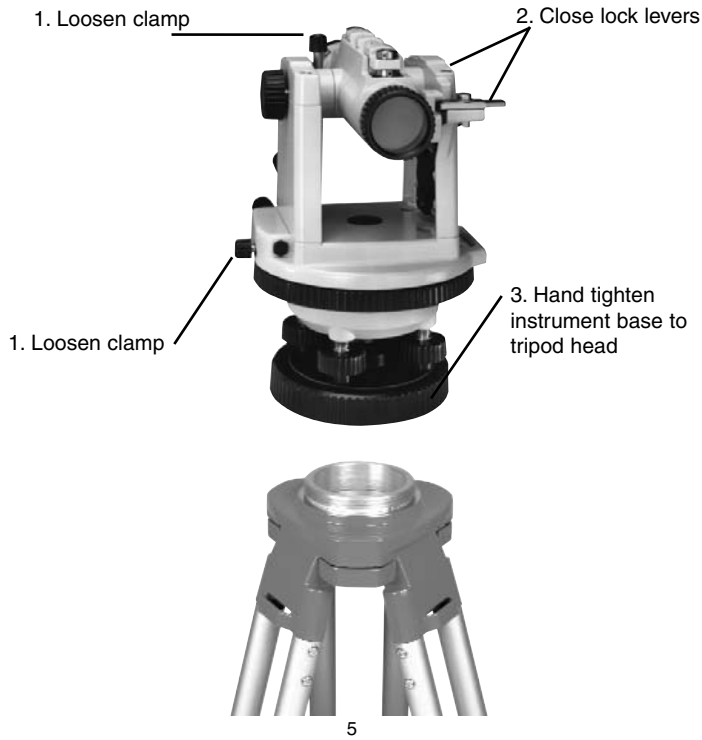

a. Start at 0 on the vernier and read up the vernier scale (in the same direction as you're reading the degree scale) until you find a minute line that coincides **exactly** with a degree line. In Figure 10a, 41° was the last degree line passed on the circle. Reading to the **right** on the vernier scale, the minute line which coincides exactly with a degree line is 25'.

Remember, each line on the vernier scale represents 5', so you will be reading 5', 10', etc.

Figure 10a

Horizontal circle reading: 41° 25'

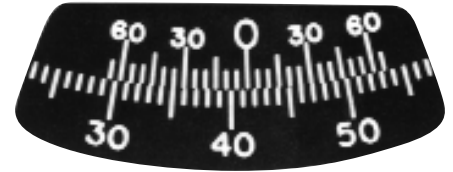

b. In Figure 10b, the circle degree scale is being read to the **left**. Reading to the **left** on the vernier scale, the minute line which coincides exactly with a degree line is 45'.

Figure 10b

Horizontal circle reading: 41° 45'



c. The vertical arc is read in the same way. In Figure 10c, 21° was the last degree line passed (when reading the arc degree scale to the **right**). Reading to the **right** on the vernier scale, the minute line which coincides exactly with a degree is 30'.

Figure 10c

Arc

Vernier Scale

Vertical arc reading: 21° 30'



Reading the circle, arc and vernier.

The 360° horizontal circle is divided in quadrants (0-90°). The circle is marked in degrees and numbered every 10 degrees. The horizontal circle is referred to as the circle or degree scale. On level-transits, the vertical arc also is a degree scale, and it is numbered every 10 degrees to 45 degrees, up and down.

For very precise readings, Universal instruments are equipped with a vernier which divides each degree on the circle or arc into 12 equal parts of 5 minutes each. There are 60 minutes (60') in a degree.

The vernier scale is read in the same direction (right or left) as you're reading the degree scale.

The following examples will explain how to read the degree and vernier scales on the circle and arc.

1. Note the point at which 0 on the vernier scale touches the circle. If the 0 coincides exactly with a degree line on the circle, your reading will be in exact degrees. There are no fractions of degrees, or minutes, to be added to the reading (Fig. 9). The vertical arc is read in the same way - if the 0 on the vernier scale coincides exactly with a degree line on the arc, the reading will be in exact degrees.

Figure 9



Horizontal circle reading: 40°

2. If the 0 on the vernier does not coincide exactly with a degree line, your **degree reading** is the line which the 0 has just passed, reading up the degree scale, **plus** a fraction of the next degree. To determine the fraction, or minutes:

3. Attach the instrument to the tripod securely, **hand tightening** the instrument base to the tripod head. If setting up over a point, use a plumb bob to center on the exact point. To hang the plumb bob, attach cord to the plumb bob hook of the tripod. Knot the cord as illustrated.



Move the tripod and instrument over the approximate point. (Be sure the tripod is set up firmly again, as described in Step 1.) Loosen leveling screws and shift the instrument laterally until the plumb bob is directly over the point. Then set the instrument leveling screws as described in Step 4.

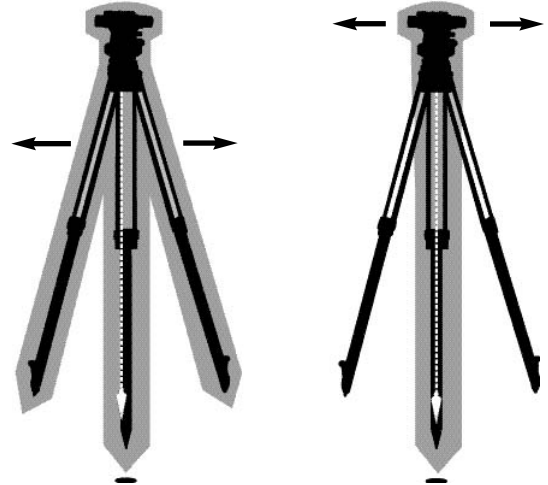

1. Move tripod and instrument over the approximate point

2. Shift instrument to line up plumb bob exactly

4. Turn down the leveling screws until firm contact is made with the instrument base. A word of caution. It is very possible to overtighten the leveling screws. You want only a firm contact between the screws and the base. If the instrument shifts on the base, turn down the screw more firmly **by hand**. If no shifting occurs, the instrument is ready for Step 5.

5. Leveling the instrument so the vial bubble remains centered through a 360° rotation of the telescope is the most important operation in preparing to use your instrument. When leveling your instrument, be sure not to touch the tripod. Follow these instructions carefully.

a. Line up the telescope so that it is directly over one pair of leveling screws. Grasp these two leveling screws with the thumb and forefinger of each hand. **Turn both screws at the same time** by moving your thumbs toward each other or away from each other, until the bubble is centered.

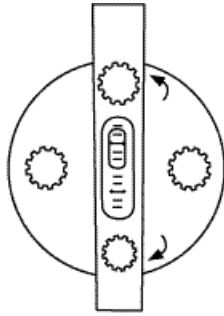

b. When the bubble is centered, **rotate the telescope 90 degrees over the second pair of leveling screws and repeat the thumbs in, thumbs out leveling procedure until the bubble is again centered.**

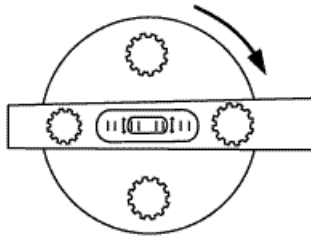

c. Shift back to the original position and check the level. Make minor adjustments with leveling screws if necessary.

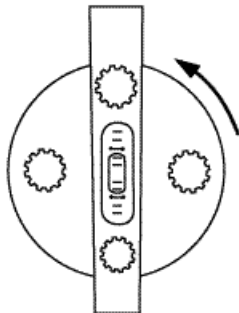

7. Line up crosshairs with the reference point (Figure 5).

8. If necessary, the instrument can be shifted laterally about $\frac{1}{16}$ " by slightly loosening the leveling screws and moving the leveling screw shifting plate on the base of the instrument (Figure 4). **IMPORTANT:** The instrument must be releveled after retightening the leveling screws.

9. If the instrument needs to be moved more than $\frac{1}{16}$ ", reposition the tripod over the reference point. Relevel the instrument.

Reattaching the tripod adapter

If the tripod adapter has been removed, it can be easily reinserted in the LT8-300P base for use with a $\frac{1}{8}$ X 11 tripod.

1. Loosen the leveling screws to allow movement of the leveling screw shifting plate.
2. Screw the tripod adapter into the instrument base until slight resistance is met.
3. If properly installed, the adapter will be flush with the instrument base as in Figure 7. Tighten securely.
4. If the adapter is not flush with the base as in Figure 8, move the leveling screw shifting plate until the center of the instrument and the center of the adapter match. Tighten securely.



Figure 7



Figure 8

- Turn the optical plummet eyepiece to bring the crosshairs into focus.

NOTE: The image seen in the eyepiece is reversed left to right. This is important to remember when shifting the instrument or tripod to center over the reference point.

- Line up the crosshairs with the reference point (Figure 5).
- If necessary, the instrument can be shifted by loosening the tripod center stud (Figure 3) and sliding the instrument from side to side for proper positioning.

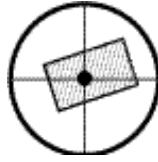

Figure 5

For use with 3 1/2 X 8 tripods:

- Line up the tripod over the reference point.
- Remove the tripod adapter by unscrewing counterclockwise from the base of the instrument (Figure 6).
- Attach the instrument to the tripod.
- Level the instrument.
- Use the optical plummet to view the reference point on the ground. Sight through the optical plummet eyepiece located beneath the telescope eyepiece (Figure 4).
- Turn the optical plummet eyepiece to bring the crosshairs into focus.



Tripod adapter

Figure 6

NOTE: The image seen in the eyepiece is reversed left to right. This is important to remember when shifting the instrument or tripod to center over the reference point.

FOR A FINAL LEVEL CHECK, rotate the telescope over each of four leveling points to be sure the bubble remains centered.

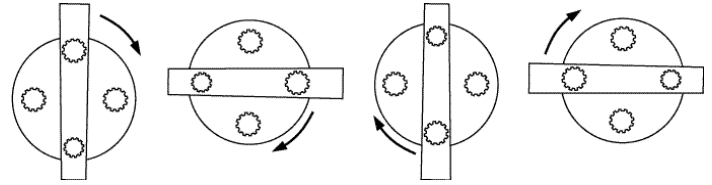

The Golden Rule for quick and simple leveling is THUMBS IN, THUMBS OUT. Turn BOTH screws equally and simultaneously. Practice will help you get the feel of the screws and the movement of the bubble. It will also help to remember that the direction your left thumb moves is the direction the bubble will move.

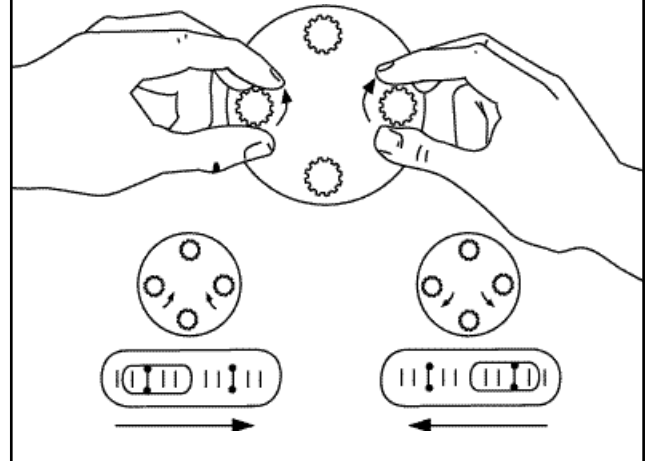

LT8-300LP

LT8-300 Level-Transit with Laser Plummet

Spec: 635nm diode. Uses a (3v) CR2 lithium battery. (Provides 60+ hours intermittent use.)

Laser Dot Size $\leq 2\text{mm}$ @2m (6').

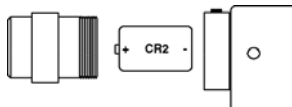

For instructions about general use, refer to the LT8-300OP instructions shown below.



The LT8-300P is shipped with a tripod adapter (P/N 44-7385) threaded into its base (Figure 2) to allow use with a $\frac{3}{8}$ X 11 tripod.

A flat head tribrach tripod (Figure 3) is recommended since the tripod's center stud shifts to allow easy setup of the optical plummet. $3 \frac{1}{2}$ X 8 thread tripods can also be used with the LT8-300P by removing the adapter; however, these tripods have no shift adjustment.

The following instructions describe setup and use of the optical plummet with either type of tripod.



Tripod adapter

Figure 2

LT8-300P

LT8-300 level-transit with optical plummet

Optical Plummet Specifications

Magnification: 1.5X

Fixed Focus: From 4'-7'

Reticle: Crosshairs, wire type, adjustable focus

Field of view: 3.5" at 5' distance

The LT8-300P is identical to the Universal LT8-300 level-transit, with the addition of the optical plummet. This feature eliminates the need to use a plumb bob. The instrument is set up over a reference point by looking through an eyepiece and optically lining up over the point. Figure 1 shows the light path through the instrument, from the reference point (a stake on the ground) to the optical plummet eyepiece.

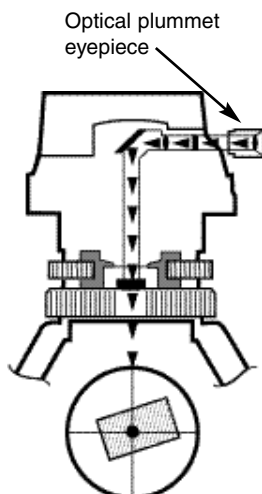
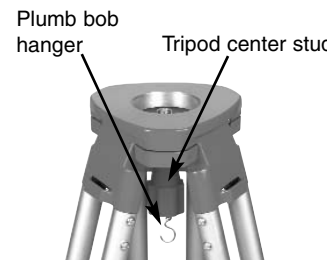

Figure 1

For use with $\frac{3}{8}$ X 11 tripods:

1. Line up the tripod over the reference point.
2. Remove the plumb bob hanger (Figure 3) from the center stud of the tripod.
3. Attach the instrument to the tripod.
4. Level the instrument.
5. Use the optical plummet to view the reference point on the ground. Sight through the optical plummet eyepiece located beneath the telescope eyepiece (Figure 4).



$\frac{3}{8}$ X 11 tribrach tripod

Figure 3



Figure 4

Leveling screw shifting plate

Optical plummet eyepiece