

Buy Now at New England Laser & Transit  
Click to Purchase

# L6-20N / LT6-900N Owner's Guide

## **David White**<sup>®</sup>

L6-20N Level and  
LT6-900N Level-Transit

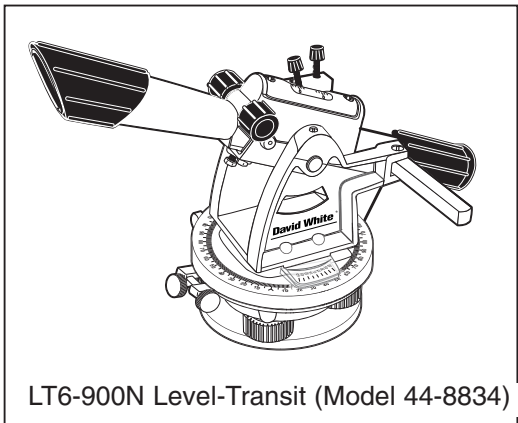
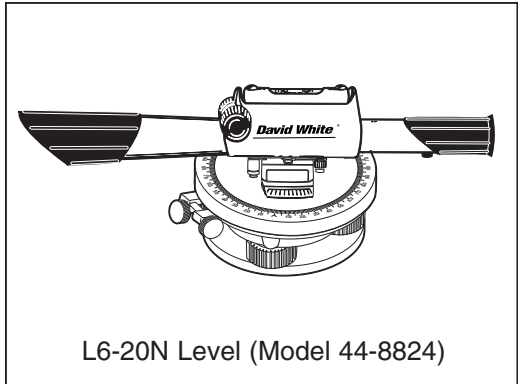

00-8830-810

For customer service, call (815) 432-9200

# **With David White your sights are set on precision and accuracy.**

Congratulations! You've purchased a David White builder/contractor instrument, American-made and known throughout the world for precision and accuracy.

The purpose of this booklet is to acquaint you with the instrument, its components, proper care and handling.

Our levels and level-transits are constructed to withstand extremely rugged field use. Like all precision instruments, however, they should be treated with reasonable care to prolong life and accuracy.

## ***David White***<sup>®</sup>

---

Quality and innovation since 1900.

All instruments are adjusted when they are shipped from the factory. It is the customer's responsibility to check and to ensure instruments are adjusted prior to using.

David White is not responsible for errors caused by instruments that are out of adjustment.

Contact your distributor, dealer or David White for information on the nearest facility to check if your instrument is properly adjusted. Some customers may choose to check the instrument themselves. This can be done by following the "Checking for Calibration" instructions at the back of this manual. All actual adjustments must be done by a qualified service facility.

All specifications are subject to change without notice.

# Specifications

## Meridian L6-20N Level

## Meridian LT6-900N Level-Transit

**Optimum sighting range:** Recommended job range up to 200 feet.

**Accuracy range:** Recommended for jobs requiring accuracy within 1/4" at 75 feet.

### TELESCOPE

Power	22X
Length	10.5" (26.5cm)
Minimum Focus	4 ft. (1.2m)
Aperture	.75" (19mm)
Field of View	2' @ 100' (.6m @ 30m)
No. of Lenses	6

---

### HORIZONTAL CIRCLE

Graduation Diameter	3.62" (92mm)
Graduations	Each 1°
Numbers	Each 10°, 0-90-0°
Vernier	Double direct to 15 min.

---

### VERTICAL ARC (LT6-900N only)

Graduations	Each 1°
Numbers	Each 10°, 45-0-45°

---

<b>CENTER</b>	Planar bearing
---------------	----------------

---

<b>LEVEL VIAL</b>	10 min. per 2mm
-------------------	-----------------

---

<b>WEIGHT</b>	L6-20N	LT6-900N
Instrument only	3.25 lbs. (1.5kg)	4.5 lbs. (2.0kg)
Instrument, case, 3 oz. plumb bob	6 lbs. 6 oz. (3kg)	7 lbs. 10 oz. (4kg)

---

<b>CASE</b>	Double-walled polyethylene
-------------	----------------------------

---

<b>TRIPOD</b>	5/8 x 11 JIS
---------------	--------------

# General Description

## Meridian L6-20N Level

## Meridian LT6-900N Level-Transit

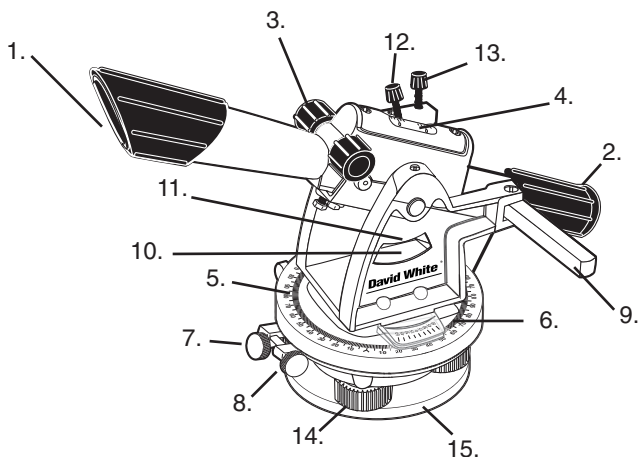
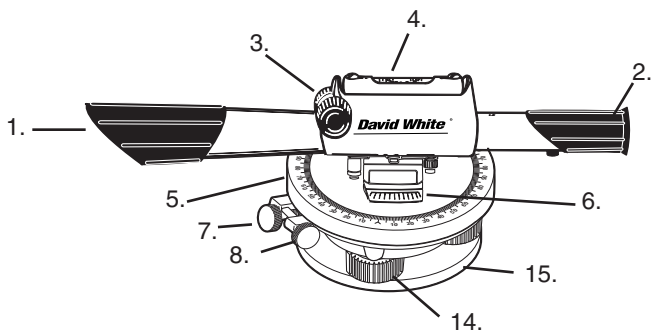

- |                                |                                |
|--------------------------------|--------------------------------|
| 1. Telescope objective lens    | 9. Telescope lock lever        |
| 2. Eyepiece                    | 10. Vertical arc               |
| 3. Focusing knobs              | 11. Vertical arc pointer       |
| 4. Instrument level vial       | 12. Vertical clamp             |
| 5. Horizontal graduated circle | 13. Vertical tangent           |
| 6. Horizontal vernier          | 14. Three leveling screws      |
| 7. Horizontal clamp            | 15. 5/8 x 11 JIS threaded base |
| 8. Horizontal tangent          |                                |

The telescope provides a sharp image magnified 22 times. This means the object sighted appears 22 times closer than it would with the naked eye. The telescope features a built-in sunshade which protects the **objective lens (1)** and reduces glare.

To focus on an object, sight through the **eyepiece (2)** and turn the **focusing knobs (3)** with either right or left hand. Cross hairs are in constant focus. All focusing is internal. The telescope does not move outward or inward as objects are focused. David White Meridian instruments use the smooth precision of a rack and pinion mechanism for focusing. Focus range is from four feet to infinity. For closer focus, turn the knob clockwise. For farther focusing, turn counterclockwise.

The instrument **leveling vial (4)** is protected by a strong, die-cast casing, and is graduated to facilitate centering the bubble.

The **horizontal circle (5)** can be rotated for easy angle setting and reading and is divided in quadrants (0-90°). The circle is marked by degrees and numbered every 10 degrees.

The **horizontal vernier (6)** permits dividing whole degrees into fractions of 1/4° (15 minutes). See page 9 for circle and vernier reading instructions.

Approximate horizontal sightings are held firmly in place by means of a **clamp (7)**. Then, precise horizontal settings can be made with the **tangent (8)**. The clamp must be hand tightened in order for the tangent to function.

#### **(THE FOLLOWING INDENTED PARAGRAPHS APPLY TO THE LT6-900N LEVEL-TRANSIT ONLY.)**

The Meridian Level-Transit is a combination instrument. Its telescope moves up and down 45 degrees, and rotates 360 degrees, to measure vertical and horizontal angles.

**The telescope lock lever (9) must be in a closed position when the instrument is to be used as a level;** open when used as a transit for vertical sightings. It is shown in the open position.

The **vertical arc (10)** is divided in degrees and numbered every 10 degrees up to 45 degrees, for both upward and downward angles, and has an adjustable **index pointer (11)**.

The **vertical clamp (12)** holds the telescope at a vertical angle. Fine vertical settings can be made with the **vertical tangent (13)**. The vertical clamp must be hand tightened before the tangent will function.

Both the L6-20N and LT6-900N have three **leveling screws (14)** for leveling the instrument. The instrument is mounted to the tripod by screwing the tripod stud into the **5/8 x 11 JIS threaded base (15)**.

# Setting up your instrument

Each of the following steps is important in preparing to use your instrument.

1. These instruments must be used with a 5/8 x 11 JIS thread tripod. For easiest setup and best operating results, it is recommended that the David White tripod is used. It is important that the tripod is set up firmly. Make sure that the tripod points are well into the ground.

When setting up on a smooth floor or paved surface, secure the points of the legs by chipping the concrete, attaching chains between the legs, or putting a brick in front of each leg. If setting up in dirt, apply your full weight to each leg to prevent settlement.

Check the tripod legs. They should have about a 3 foot spread, **positioned so the top of the tripod head appears level.**

If using a tripod with adjustable legs, be sure the leg levers are securely tightened.

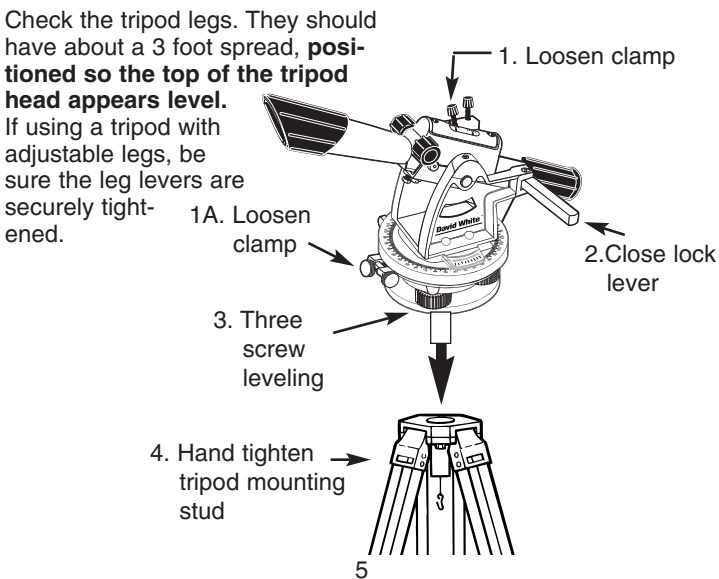
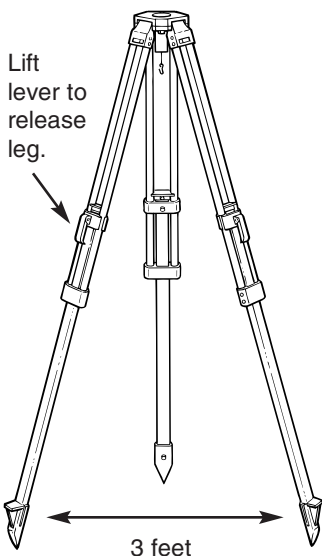

**2.** Before setting up your instrument, loosen the clamps. If using the level-transit, be sure the telescope lock lever is in the closed position. Attach the instrument to the tripod securely, **hand tightening** the tripod mounting stud to the instrument base. If setting up over an exact point, read step 3; otherwise, continue to step 4.

**3.** If setting up over a point, use a plumb bob to center on the exact point. To hang the plumb bob, attach cord to the plumb bob hook on the screwdriver-style handle of the tripod. Knot the cord as illustrated.

Move the tripod and instrument over the approximate point. (Be sure the tripod is set up firmly again, as described in step 1.) Shift the instrument on the tripod head until the plumb bob is directly over the point. Then set the instrument leveling screws as described in step 4.

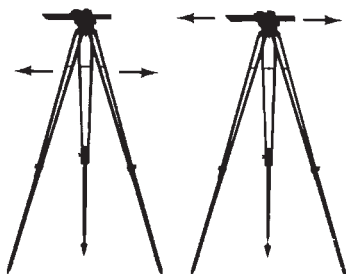

1. Move tripod and instrument over the approximate point.

2. Shift the instrument to line up plumb bob exactly.



### **Hanging the plumb bob.**

To hang the plumb bob, attach cord to the plumb bob hook on the tripod and knot the cord as illustrated.

#### 4. LEVELING THE THREE SCREW INSTRUMENT

Instruments utilizing three leveling screws are mounted on the tripod and leveled in the following manner:

Mount the instrument on the tripod. Lock the telescope in place with the lock lever and line up the telescope vial in position #1 as shown (Fig. 2). Then grasp screws A & B so that both thumbs are moving in opposite directions, either toward each other or away from each other. Note that the bubble moves in the same direction as your left thumb. Do not permit the screws to come completely out of their bushings.

Keep about half the length engaged. When the bubble is centered in position #1, turn the instrument and observe the vial in position #2. Now center the bubble in position #2 using only screw C.

Your David White Instrument should now be leveled up, but to be certain, double-check. Rotate the instrument 180° so the vial is reversed. If the bubble will not center when reversed, follow adjustment procedure outlined under "Bubble Adjustments."

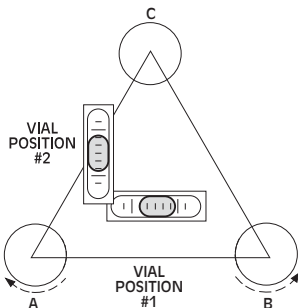

**NOTE:** Bubble adjustments must be correct if proper results are to be obtained using the instrument.

## BUBBLE ADJUSTMENTS

If the telescope bubble does not remain centered after having leveled the instrument, and reversed the telescope end for end ( $180^\circ$ ) (as described under the chapters entitled "Leveling the...Instrument") the need for adjustment is indicated. Use a screwdriver. .

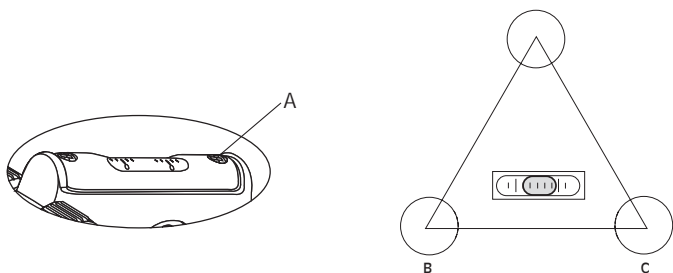

With an adjusting screw "A" facing to the right of the bubble and with telescope directly in line with two of the three leveling screws, note to which side the bubble is off. If to the left, loosen screw "B" very slightly to remove ONE-HALF the error. Remove the other half of the error with the two level screws in line with the telescope. If the bubble is still not exactly centered, repeat the procedure.

If bubble is off to the right, tighten screw "A". Otherwise, the procedure is identical (Fig. 3).

# Reading the circle and vernier

The  $360^\circ$  horizontal circle is divided in quadrants ( $0$ - $90^\circ$ ). The circle is marked by degrees and numbered every 10 degrees. To obtain degree readings, it is only necessary to read the exact degree at the intersection of the zero index mark on the vernier and the degree mark on the circle (or on the vertical arc of the level-transit.)

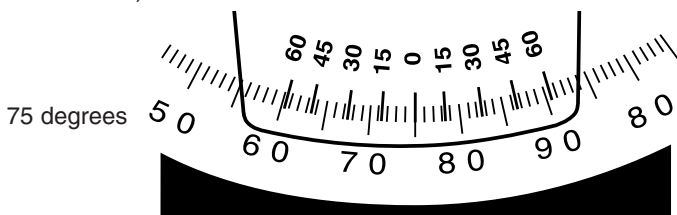

For more precise readings, the vernier scale is used. The vernier lets you subdivide each whole degree on the circle into fractions, or minutes. There are 60 minutes in a degree. If the vernier zero does not coincide exactly with a degree mark on the circle, note the last degree mark passed and, reading up the vernier scale, locate a vernier mark that coincides with a circle mark. This will indicate your reading in degrees and minutes.

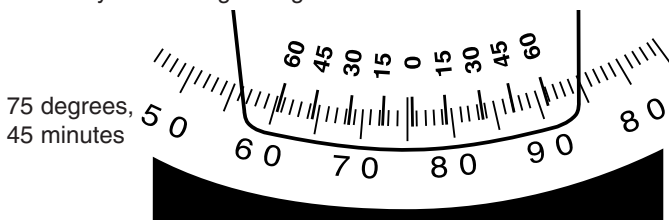

## Sighting and focusing the telescope

Aim the telescope at the object and sight first along the top of the telescope tube. Then look through the telescope and adjust the focus.

When cross hairs are positioned on or near the target, tighten the horizontal clamp and make final settings with the tangent to bring the cross hair exactly on point.

When sighting through the telescope, keep both eyes open. You will find that this eliminates squinting and will not tire your eyes. Remember to avoid touching the tripod while sighting.

## Removing the instrument from the tripod

Loosen two adjacent leveling screws and unscrew the tripod mounting stud while holding onto the instrument. Remove the instrument from the tripod and secure it in its protective carrying case. Loosen the vertical clamp and close the lock lever on the level-transit. Center the telescope in the case.

## Care and handling

1. Keep the instrument clean and free of dust and dirt. Clean the objective and eyepiece lenses using a soft brush or lens tissue. Rubbing with a cloth may scratch the lens coating and impair the view. Clean the instrument with a soft, non-abrasive cloth and mild detergent. Never use solvents or submerge the instrument in water. Do not attempt disassembly.
2. If the instrument is wet, dry it before you return it to its case.
3. When the instrument is not being used, keep it in its carrying case.
4. When moving the instrument over a long distance, by foot or by vehicle, remove it from the tripod and place it in its protective case.
5. When moving a tripod-mounted instrument, handle with care. Carry only in an upright position. Do not carry over your shoulder or in a horizontal position. Improper handling may result in instrument damage.
6. Handle the instrument by its base when removing from the case or attaching to a tripod.
7. Never use force on any parts of the instrument. All moving parts will turn freely and easily by hand.
8. All precision instruments should be cleaned, lubricated, checked and adjusted **ONLY** at a qualified instrument repair station or by the manufacturer, at least once a year.

# Using your instrument

Levels and level-transits, as do all sighting instruments, operate on the principle that any point along a level line of sight is exactly level with any point along that line.

## Levels and level-transits

The following jobs can be accurately performed with a level or level-transit used in the level position (with closed lock lever): grading for swimming pools, driveways, sidewalks, lawns, gardens; plotting contour plowing lines; laying out drainage ditches; setting fence lines; estimating cut and fill requirements; setting forms and footings; leveling walls and foundations; establishing drainage for landscaping; aligning trees and shrubs and building terraces and stone walls.

## Determining differences in elevation

One of the main uses of levels is for measuring the differences in elevation for grading.

With the instrument leveled, we know that since the line of sight is perfectly straight, any point on that line of sight will be exactly level with any other point.

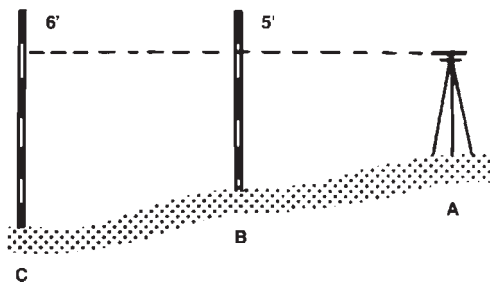

The above illustration shows how exactly we can check the difference in height (or elevation) between two points. If the rod reading at B is 5 feet and the reading at C is 6 feet, we know that point B is 1 foot higher than point C. Using the same principle, you can easily check if a row of windows is straight, or a wall is level, or how much a driveway slopes.

## Running straight lines with a level

Set up the instrument over Point A. A plumb bob should be held over Point B. Sight approximately on the plumb bob cord and turn the telescope so that the vertical cross hair coincides with it. To align the intermediate points, direct the person with the leveling rod to the right or left until the rod coincides with the vertical cross hair. It is important not to move the instrument during operation. After all points have been set, check back on point B to be sure that the instrument did not move.

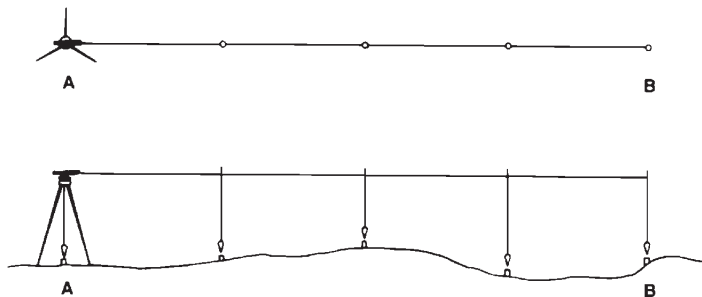

## Determining contour lines

Contour lines, such as used for contour plowing, are lines connecting points of equal level. To determine contour lines, first level the instrument carefully. A sighting rod should be held at the beginning contour line about 100 feet from the instrument. Sight the rod and set a target on the rod at the point where the horizontal cross hair intersects the rod. Then move the rod to approximately the next place where a contour line stake is to be set and move the rod up or down the slope until the line of sight through the telescope again intersects the target. This determines a second point on the contour line. This step is repeated as many times as necessary.

If the person holding the rod is moving too far from the instrument, simply hold the rod in one of the positions determined from the original instrument position and move the instrument to another convenient location along the contour. Sight on the rod in this position and move the target up or down until it lines up with the cross hair. The line may then be continued in the same manner as before.

## Measuring and laying out angles

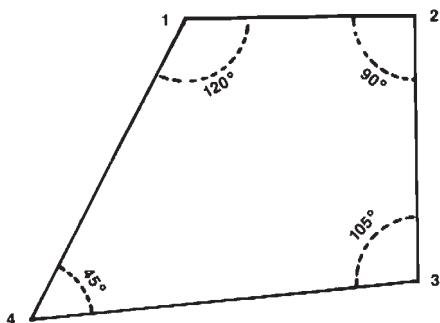

For measuring angles, attach a plumb bob cord to the hook on the screwdriver-style handle of the tripod. The point of the plumb bob will then indicate a point on the ground directly below the center of the instrument and, therefore, will also indicate the center of all angles to be measured. This point should be marked by a stake about two inches square with a tack indicating its center.

Horizontal angles are always read at the vernier zero mark. (See "Reading the circle and vernier," page 9.) The following example simply explains how to measure angles:

Set the instrument up at station 1. Place it so the plumb bob is directly over station 1. Now level the instrument as explained previously. Turn the telescope so that the vertical cross hair is directly in the center of the rod at station 2. Set the horizontal circle at zero to coincide with the vernier zero. Then turn the telescope to sight on station 4 and read the angle. (In this case, it would be 120 degrees.)

Move the instrument and tripod to station 2 and level exactly as before. When the instrument has been leveled, sight back to read on station 1. Set the horizontal circle to zero, then sight the telescope to locate station 3 and read the angle (90 degrees). Move the instrument and tripod to station 3 and level as before. Again, sight back to the previous station (2) and set the circle at zero. Turn the telescope to sight on station 4. Your angle should be 105 degrees. The same procedure is followed to measure the angle at station 4.

You can prove the accuracy of your reading by adding the four inside angles together because the total of the inside angles of a quadrangle is always 360 degrees.

To lay out an angle, proceed in the same way as in measuring an angle. Set the instrument at station 1, level it, and set the circle at zero. Swing the telescope to the desired angle and move the rod to intersect the vertical cross hairs. This establishes your angle.

**NOTE:** The L6-20N and LT6-900N have horizontal verniers which read to 15 minutes (1/4 degree). For projects which need more accurate angle measurement for layout, we recommend using a more precise instrument with a 5 minute vernier.

## Laying out a swimming pool

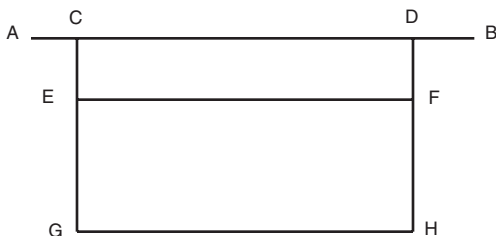

In the above figure, A-B is the lot line. The corner of the proposed swimming pool is E. Point C is the point where the line forming the side of the pool intersects this lot line. If E has not already been determined, set up and level the instrument directly over point C and line up the cross hairs on B. Set horizontal circle to zero. Turn the telescope 90 degrees to the right.

The vertical cross hair of the instrument will now cut across point E and point G. Measure the distance from the lot line to the corner of the pool, which is C-E. Also, the distance E-G is measured along this line. Place a stake at points C, E and G.

Next set up and level the instrument directly over point E and line up the cross hairs on G. Set reading to zero. Turn the telescope 90 degrees to the left to establish the line E-F. Measure out the distance and place a stake at point F. The distance, D-F, (from F to the lot line) will exactly equal E-C if the work is correct.

Next set up and level the instrument over point F and set the vertical cross hair at point E. Set reading to zero. Turn the telescope 90 degrees to the left to establish the line F-H. Measure out the distance and place a stake at point H.

# Using your instrument

## Level-transits

The following example illustrates how to use a level-transit for laying out roads, building lines, ditches, orchards, fences, hedges, fields, etc.

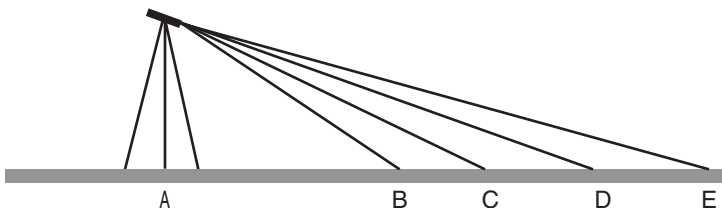

## Running straight lines with a level-transit

(Although it is possible to run straight lines with a level, it is faster and more accurate to use a level-transit.)

To run a straight line between stakes A and E, position the instrument directly over A. After you level the instrument, release the lock that holds the telescope in the level position and swing the instrument until point E is aligned with the vertical cross hair.

Tighten the horizontal clamp so the telescope can move only in a vertical plane. By pointing the telescope up or down, points B, C and D can be located.

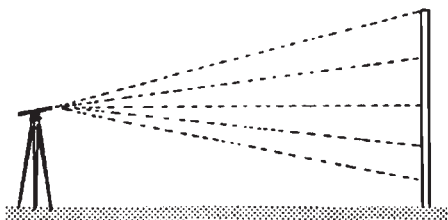

## Establishing vertical lines and planes

It is necessary to use a level-transit instrument for taking vertical sights, such as lining up a building wall, aligning piers or fencing, flagpoles, T.V. antennas, plumbing windows or doorways, etc.

To establish vertical lines and planes, first level the instrument, then release the locking levers which hold the telescope in the level position. Swing the telescope vertically and horizontally until the line to be established is directly on the vertical cross hair. If the telescope is rotated up or down, each point cut by the vertical cross hair should be in a vertical plane with the starting point.

**All components not described on pages 3 and 4 including adjustment screws and nuts, have been factory set and should not require handling or readjustment. Tampering with these factory-adjusted components may impair accuracy or damage the instrument. Only trained technicians should service this instrument.**

## **Instrument service and repair**

Your David White instrument is a precision-made optical instrument and like all good precision tools requires reasonable care and careful handling. It is recommended that all instruments be serviced by a reliable instrument repair station at least once a year to insure accuracy and reliable performance.

If the instrument has been dropped or severely jarred, the instrument's line of sight may be affected. The line of sight must be exactly perpendicular to the vertical axis of the instrument. This is checked by the two-peg adjustment system. This method is a specialized procedure and should be conducted only under ideal conditions and only by qualified instrument personnel.

**For Customer Service, Parts, and Repair  
Call**

**1-815-432-9200**

Customer Service E-Mail: [custserv@davidwhite.com](mailto:custserv@davidwhite.com)

# Checking for calibration

Your David White instrument must be serviced and repaired by an authorized David White service center. You may, however, choose to *check* the instrument yourself to make sure it is properly adjusted. A simple, inexpensive setup can be established to check an instrument's line of sight:

1. Locate an area to set up a tripod that is 10 feet away from a wall, post, permanent shelving, etc. and approximately 75 feet to 100 feet away (at a 90° angle) from another wall, post, etc.
2. Using an automatic level or other high-accuracy instrument known to be in perfect adjustment, secure it to the tripod and level it following instructions in the instrument's owner's manual.
3. Make sure the tripod is on a firm base and mark the location of the tripod shoe points. These marks can be used for future reference.
4. After the instrument has been completely leveled, sight on the wall that is 10 feet away.
5. Place a two-foot section of rod ribbon on the wall so the horizontal cross hair of the instrument intersects the middle of the two-foot section.
6. Rotate the instrument 90° and sight on the wall that is about 75 feet to 100 feet away.
7. Place a two-foot section of rod ribbon on that far wall so the horizontal cross hair of the instrument intersects the middle of the two-foot section (as in Step 5). Adjust this rod ribbon so that it reads the same exact point as the closer ribbon. Secure ribbon with tape or glue.
8. Now put the instrument to be checked on the tripod and take a reading on the ribbon 10 feet away. Record the reading.
9. Rotate the instrument 90° and take a reading on the distant ribbon.
10. Compare the two readings. If there is a difference in the two readings, your instrument needs adjusting by a David White service facility.

**If you have questions about checking for calibration, contact David White or a repair facility. All actual adjusting of the instrument must be done by a qualified service facility.**

For your records

Model No. • L6-20N • LT6-900N

Date purchased \_\_\_\_\_ Serial No. \_\_\_\_\_

For owner identification, please complete and mail the attached registration card.

## Limited Lifetime Warranty

David White ("Seller") warrants this David White optical instrument to be free from defects in material and/or workmanship. If, upon inspection, this instrument shall be proven to Seller's satisfaction to be defective, it shall be repaired or replaced, at Seller's option at no charge and returned to the original purchaser ("Buyer"), transportation prepaid. This warranty is not transferrable. Seller's sole obligation and Buyer's remedy hereunder shall be limited to such repair or replacement with these provisions:

1. The instrument is returned properly packaged, transportation prepaid and insured by the Buyer to David White accompanied by proof of ownership (copy of sale or receipt).
2. The instrument, upon inspection of Seller, is determined to be defective due to material and/or workmanship and is in original condition, excepting only ordinary wear resulting from normal usage.

SELLER SHALL NOT BE LIABLE FOR ANY CONSEQUENTIAL, INCIDENTAL OR CONTINGENT DAMAGES WHATSOEVER

### Limitations and Exclusions

1. The foregoing warranty does not apply to David White instruments subjected to negligence, accident, improper operation or maintenance or storage; instruments damaged by transit or circumstances beyond Seller's control; instruments modified or damaged due to unauthorized repairs made by other than David White or authorized David White service center personnel.
2. The foregoing warranty does not apply to instrument accessories or include general maintenance and service such as cleaning, lubrication or adjustment (i.e. calibration) of this instrument unless required as a result of a material or workmanship defect.  
If, upon examination of instrument, Seller determines that additional repairs or services not covered under this warranty are required, Seller shall notify Buyer of such charges and will proceed with said services or repairs only after authorization is received from Buyer.
3. The foregoing warranty does not apply to David White instruments damaged in transit to or from David White or a David White authorized service center.

THE FOREGOING WARRANTIES ARE EXCLUSIVE AND IN LIEU OF ALL OTHER WARRANTIES, EXPRESS OR IMPLIED, INCLUDING, BUT NOT LIMITED TO, THE IMPLIED WARRANTIES OF MERCHANTABILITY AND FITNESS FOR A PARTICULAR PURPOSE.

### David White

P.O. Box 359, Watseka, IL 60970 USA

URL:<http://www.davidwhite.com>

W44-8830-810

TJOP

(0305)REV.1