

Buy Now at New England Laser & Transit [Click to Purchase](#)

# AGL

**CONSTRUCTION LASERS  
& MACHINE CONTROL SYSTEMS**



## EAGL 1-Touch Laser Level

Owner's Manual

# GENERAL INFORMATION

Thank you for buying the EAGL 1-Touch laser. Although it is very simple to use, we recommend that you read this manual before operating the laser.

## Specifications

|                       |   |
|-----------------------|---|
| Operating range       | 1,500 ft. (450m) diameter   |
| Self-leveling range   | $\pm 4^\circ$ ( $\pm 7\%$ )   |
| Accuracy              | Better than $\pm 1/16''$ @ 100' ( $\pm 4\text{mm}/100\text{m}$ )<br>$\pm 8$ arc seconds   |
| Rotation speed        | 600 rpm   |
| Beam type/output      | Infrared diode; 785nm; 1.0mW; Class 1   |
| Power sources         | (1) 4 "D" size alkaline battery pack<br>(2) optional NiCd rechargeable battery pack<br>(3) AC charger with optional NiCd battery pack |
| Battery life          | Approximately 100 hours (alkaline)<br>40 hours (NiCd)   |
| Mounting base         | 5/8" x 11 flat or domed   |
| Water resistance      | IP55  |
| Operating temperature | 14° to 122° F (-10° to 50° C)   |
| Storage temperature   | -4° to 140° F (-20° to 60° C)   |
| Dimensions            | 8" h x 6.5" w x 6" d (20 x 16 x 15cm) 5 lbs. (2.3 kg)   |

## Overview of Laser & Keypad

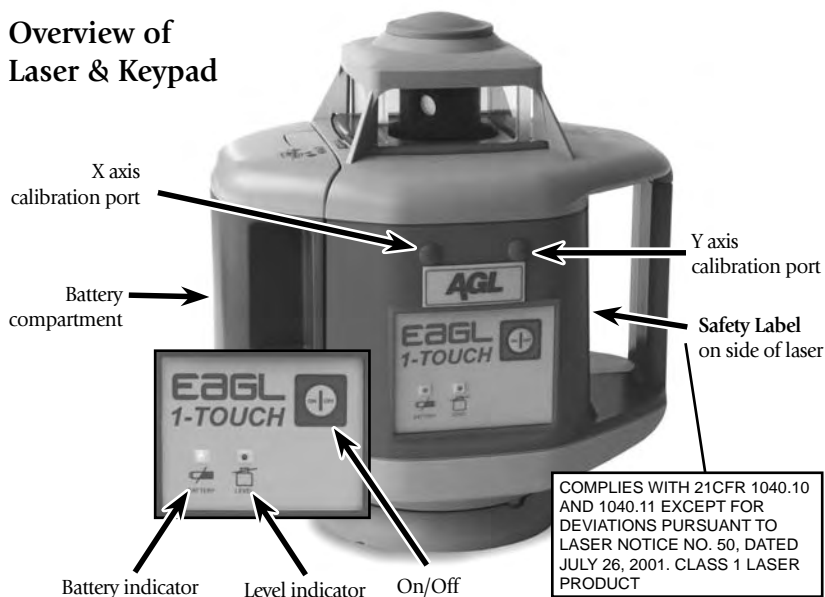

# OPERATION

## Setup

The laser mounts to any 5/8" x 11 tripod (flathead or domed) or can rest on any stable flat surface (floor, bricks, etc.). Position tripod, attach laser, then adjust tripod until rough leveled (within  $\pm 4^\circ$  self-leveling range).

## Turning on the Laser

Press the on/off key to power-up the laser. The unit's self-checking system will start automatically. Both LEDs will flash if anything goes wrong during the self-check procedure. The battery LED should be green (if batteries are low, LED will be red).

## Leveling

When laser is turned on, the level indicator will flash red until unit is level. If it fails to self-level within 90 seconds, the red LED will be constantly lit. Re-adjust tripod to bring into self-leveling range. When unit is level, the rotor head will begin spinning (600 rpm).

## Level Alert

If laser is disturbed, the level alert system will stop head rotation. Unless disturbed out of self-leveling range ( $\pm 4^\circ$ ), unit will self-level and return to operation automatically. Always recheck beam height against benchmark when releveling is required.

## Checking Your Laser

The laser is a precision instrument and it is important that you keep it calibrated and in proper condition. The accuracy of your work is completely your responsibility and you should check your instrument daily, or at a minimum before beginning each job, and definitely after the instrument has taken a sharp jolt or been dropped, or when temperature changes greater than 50 degrees F (28 degrees C) have occurred. See simple instructions to check calibration in this manual.

## Power Sources

The laser can be operated from the alkaline battery pack (4 D-size batteries) or the optional NiCd rechargeable battery pack (charge before first use).

The NiCd battery pack can also be charged while working. If electricity is available on the job site, simply plug in the charger and keep working.

# BATTERY PACK

To replace the alkaline batteries, or to charge the NiCd pack, first remove the battery pack. The NiCd pack must be charged before first use.

## Removing the Battery Pack

1. Press the battery unlock button -- see (1) in the diagram at right.
2. Supporting the battery, press battery release (2) to remove it.

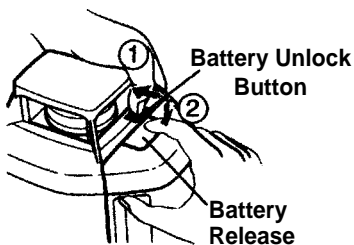

## A) Battery Replacement

1. Raise the battery cover release to remove the battery cover.
2. Insert 4 D batteries. The insertion direction of the batteries is indicated on the battery pack.
3. Attach the battery cover, inserting the guide lips into the guide slots.

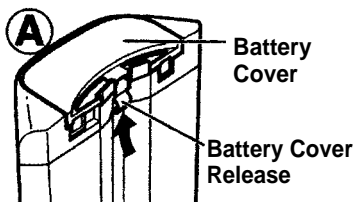

## B) Recharging (optional NiCd pack)

1. Remove charging connector cap on the battery pack and plug in the charger.
2. Plug charger into electrical outlet. A red light on the charger indicates it's charging.
3. When the red light blinks (lights on for 6 seconds, off for 20 seconds), the charging is finished. Charging time is about 7.5 hours. The unit can be charged while working. For optimum life of the battery, it's recommended to charge the battery after fully discharged. To assure battery life, do not charge over 20 hours.

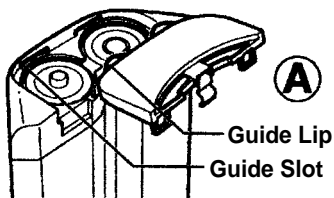

## C) Installing the Battery Pack

1. Fit the guide posts of the battery into the guide slots of laser.
2. Attach the battery to the laser by pressing the top of the battery against the laser until a click is heard.

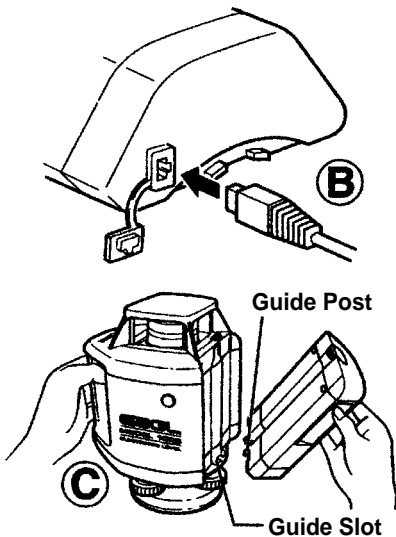

# CALIBRATION

Calibration should be checked regularly. For convenience you should establish a range for routine, quick checks. Your AGL dealer can assist you in setting up one.

Allow at least 15 minutes of warm-up time before checking or adjusting calibration. Steps 1-7 deal with checking calibration. If adjustment is needed, Steps 8-12 explain the procedure. Follow the instructions carefully.

## Checking Calibration

1. Select a level range at least 100 ft. (30 m) long. Set up the laser on a flat surface or tripod. Approximately 100 ft. (30 m) away, erect a vertical pole or rod.
2. Position laser so one axis is aligned toward pole at end of range.
3. Turn laser on and allow to level.
4. Using a detector, mark elevation of beam at pole (this is mark A).
5. Rotate laser 180° so the axis is again aligned with pole but in opposite direction. Use detector again to mark elevation of beam on pole (mark B).
6. If marks "A" and "B" are within 1/8" (2.5 mm), calibration is correct.
7. Repeat the above procedure for the other axis. If marks are more than 1/8" (2.5 mm) apart, proceed to Step 8 for calibration adjustment.

## Calibration Adjustment

8. Make new "A" and "B" marks (repeat Steps 2-7). Make a third mark halfway between the new "A" and "B". Call this mark "C". This is the correct beam center.
9. The calibration port for each axis is located on the top front of the laser (see photo on previous page). Choose the port matching the axis you are calibrating. Open only one cover at a time to avoid adjusting the wrong axis.
10. Using a small screwdriver, carefully turn the exposed calibration port until beam is centered at mark "C". Make adjustments in small, careful increments. After each adjustment, check beam movement at the pole.
11. Double check the axis. Rotate the laser 180° and again check the beam. Beam should now strike within 1/16" (1.5 mm) of mark "C". If not, repeat Steps 8-10, adjusting as needed until axis is calibrated.
12. Repeat Steps 2-11 for the other axis. Calibration is complete when mark "C" is the same for both axes in both directions.

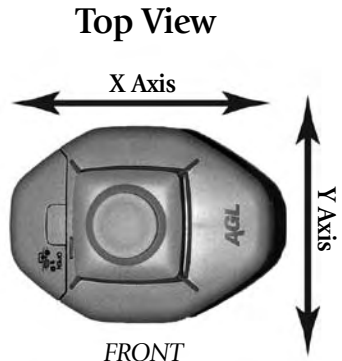

*If you experience difficulty or have questions regarding this procedure, call your AGL dealer or the factory. Our toll-free number is 1-800-643-9696. Outside the continental U.S., call 501-982-4433.*

# DETECTOR

## LS-50 Detector for Grade Rod or Handheld Applications

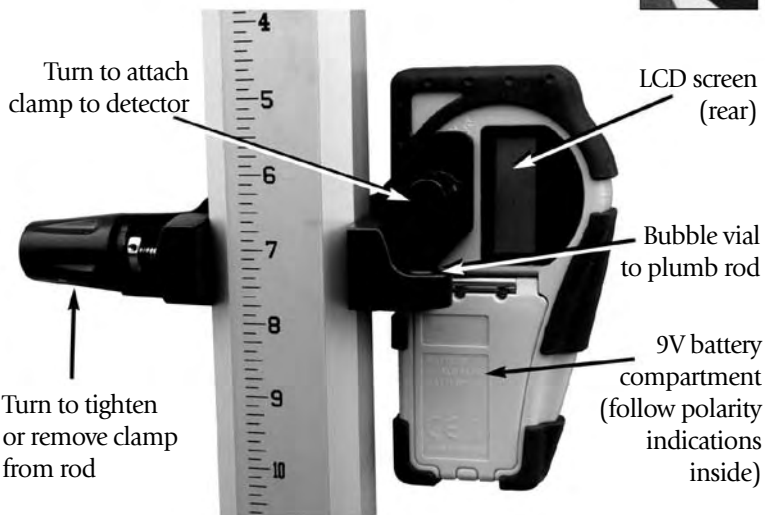
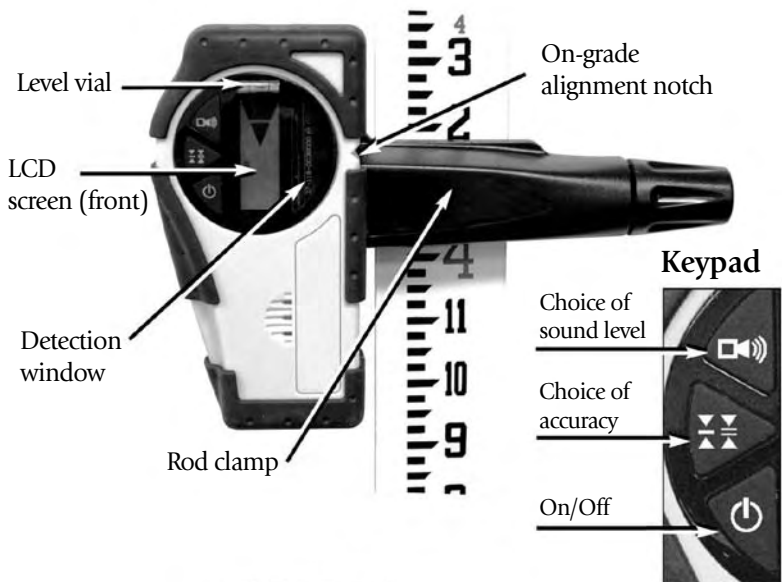

# LCD Display

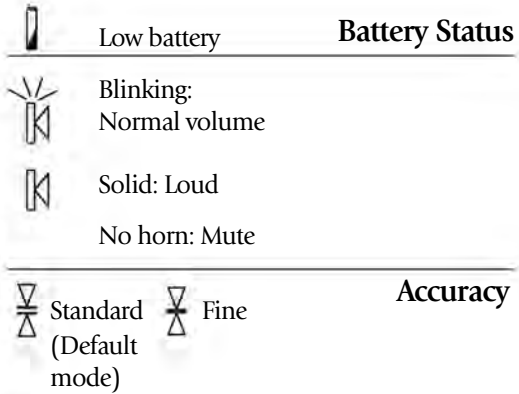
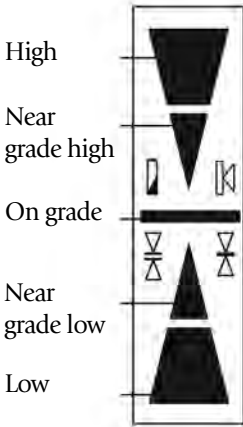

## Using the Detector

- 1) Press the On/Off key to turn on the detector.
- 2) Press the middle key to select the accuracy (deadband).
- 3) Press the top key to select the sound level.
- 4) Turn the detection window towards the laser beam, and move the detector up or down according to the information given on the LCD display. There are five channels of information, or grade indicators. A down arrow indicates you must move the detector down to reach the laser reference; an up arrow, move it up. When a horizontal line appears on the display, the detector is at the same level as the laser beam.
- 5) Press the On/Off key to turn the detector off. It will automatically shut off after ten minutes if not used (and give a warning beep).
- 6) Keep the detection window clean, using a soft cloth and glass cleaner.

## Specifications

|               |  |
|---------------|--|
| Range         | 750 ft. (225m)   |
| Accuracy      | Fine: $\pm < 1/16''$ (1 mm)<br>Standard: $\pm 1/8''$ (2.5mm) |
| Battery life  | 50 hrs; 9V alkaline  |
| Environmental | Waterproof (IP66+)   |
| Size          | 6" x 3.25" x 1.5"; .35 lbs. (15 x 8 x 3.5 cm; .2 kg)         |

## AGL Limited Warranty

**EXPRESS WARRANTY FOR HARDWARE.** AGL Corporation ("AGL") warrants to the original end user ("Customer") that this Product will be free from defects in workmanship and materials, under normal use, for one (1) year and non-AGL-manufactured products for which ninety (90) days shall apply, unless such warranty period has been extended by AGL, and provided any and all operating and maintenance instructions are strictly respected, in particular in case of extreme and/or continuous applications/use of the Product. The warranty period begins on the proved purchase date, or if applicable, date of delivery or date of acceptance report. AGL's sole obligation under this express warranty shall be, at AGL's sole option and expense, to replace or repair the Product or part, or refund the purchase price paid for the Product. AGL warrants any repaired or replaced Product or part for a period of ninety (90) days from shipment, or through the end of the original warranty, whichever is longer. All Products or parts that are replaced become the property of AGL. This express warranty does neither cover consumables, such as batteries, bulbs and fuses, nor third party products.

**OBTAINING WARRANTY SERVICE.** Customer must contact an authorized service center of AGL or AGL's Service Center within the applicable warranty period to obtain warranty service authorization. Dated proof of original purchase from AGL's authorized distributor and a description of the defect will be required. AGL is not responsible for Products or parts received without a warranty service authorization. Repaired or replacement Products will be shipped to Customer at AGL's expense. The repaired product or part will be shipped as soon as reasonably possible. AGL shall not be responsible for any damages occurring during such shipment. For Products forming part of a fixed installation, such place of performance shall be the site of such installation and AGL shall have the right to charge for additional costs for such services under warranty if the site of the Product is other than where the Product was originally shipped or installed.

**WARRANTY EXCLUSIVE.** Customer's sole remedy for breach of the warranty shall be the express warranty. The foregoing warranty is exclusive and is in lieu of all other warranties, terms, or conditions, express or implied, either in fact or by operation of law, statutory or otherwise, including warranties, terms or conditions of merchantability, fitness for a particular purpose, satisfactory quality and non-infringement, all of which are expressly disclaimed. AGL shall not be liable if the alleged defect or malfunction was caused by Customer's or any other person's misuse, neglect, improper installation, unauthorized attempts to open, repair or modify the Product, inadequate maintenance, disregard of operating instructions, excessive load or stress, normal wear and tear, or any other cause beyond the range of its intended use, by accident, fire, or other hazards, or other cause not due or attributable to AGL. This warranty does not cover physical damage to the Product or malfunctions resulting from the use of the Product in conjunction with any sort of ancillary or peripheral equipment and AGL determines that there is no fault with the Product itself.

**LIMITATION OF LIABILITY.** AGL also excludes any liability, whether based on contract or tort (including negligence), for incidental, consequential, indirect, special, or punitive damages of any kind, or costs of procurement of substitute products by customer, or for the loss of revenue or profits, loss of business, loss of information or data, or other information or financial loss arising out of or in consequence with the sale, installation, maintenance, use, performance, failure, or interruption of this product, even if AGL or its distributors have been advised of the possibility of such damages, and limits its liability to replacement, repair, or refund of the purchase price paid, at AGL's option. This limitation of liability for damages will not be affected if any remedy provided herein shall fail of its essential purpose.

**DISCLAIMER.** Should a court of jurisdiction not allow the entire exclusion or limitation of implied warranties or the limitation of incidental or consequential damages for certain products supplied to Customers, or the limitation of liability for personal injury, such implied warranties and such liabilities will be limited to the duration of the applicable express warranty.

With this Limited Warranty, AGL grants Customer specific legal rights which do not restrict any statutory consumer rights. This Limited Warranty shall be governed by the laws of Arkansas, USA.



2202 Redmond Rd., Jacksonville, AR 72076  
sales@agl-lasers.com • www.agl-lasers.com

Toll Free: 800.643.9696 Fax: 501.982.0880 Phone: 501.982.4433